

RADIO AMATEUR CLUB STATION OF TEXAS INSTRUMENTS GERMANY

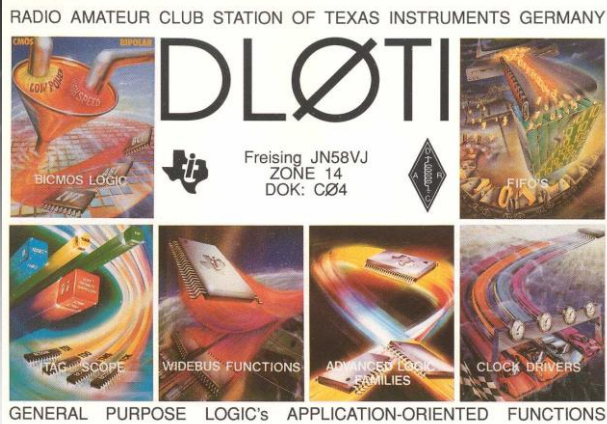

DLØTI
Freising JN58VJ
ZONE 14
DOK: CØ4

GENERAL PURPOSE LOGIC's APPLICATION-ORIENTED FUNCTIONS

AMATEUR RADIO CLUB STATION OF TEXAS INSTRUMENTS IN FREISING, GERMANY



TEXAS INSTRUMENTS DLØTI

Presentation “QRO PA” at OV P14

Solid State LDMOS based RF Amplifier “QRO PA” home-brewed

Matthias Ulmann,
Bernd Geck,

DK9MAT
DB3GF/DLØTI & 9A8ABG,

Amplifiers homebrewing – WHY ?

- Legal output power for shortwave radios at Germany is 750W, legal limit for the United States is 1500W – the market for high power amplifiers is low and in some cases electrical robustness of solid state amplifiers is poor
= sensitive commercial amplifiers, protections lacking or even missing
- The quality of commercial amplifiers could be fairly bad - spurious emissions, mechanically sloppy, noisy fans
= poor quality by low cost design
- Most commercial amplifiers are designed for smallest size, so the thermal interface is not able to cover long term high power transmission, not suited for “contest” use (QRO PA 18.2kg, width 40.5cm / height 20.5cm / length 34.5cm)
= low endurance at full power and 50% RX / 50% TX

Amplifier homebrewing – WHY ?

TEXAS INSTRUMENTS stands for quality, performance and power; club radio station DL0TI will do so as well:



DL0TI on air until March – by tube



April 2021 – 2x LDMOS acting now

Short Introduction to RF Amplifiers

- In the past – and still common in RF: TUBE AMPLIFIERS

PRO's - a tube, especially a metal ceramic tetrode is electrically robust,
i.e. Svetlana GU-74b, suited for 1kW output power, accepts
up to 240W reflected power short term and 120W long term
- single variable PI filter transfers power to antenna, better 50dBc

CON's - mechanically sensitive on shock and vibration
- aging, tube loses vacuum over the years, needs replacement
- typically needs preheating 90secs to 180sec
- high plate voltage, grid voltage, heater voltage = sophisticated supply,
in most cases less efficient linear power supplies
- typically limited gain, +10dB..+20dB, but depending on topology

Short Introduction to RF Amplifiers

- In this day and age: SOLID STATE AMPLIFIERS (here LDMOS based)

PRO's - almost no aging of bipolar or LDMOS devices

- mechanically robust regarding shock and vibration
- no preheating needed, just go ON AIR as you want
- simple reuse of 48V telecom rectifier to supply 50V devices, so low EMI, having PFC (no reactive power) and PSU efficiency 96%
- better RF efficiency, especially by enabling digital predistortion
- high gain, up to 30dB - and still linear operation

CON's - LDMOS are extremely sensitive on overdrive (gate voltage)

and reflected power (drain voltage), needs to be less than 50W (!)

- needs a low pass filter per band to attenuate spurious emissions

Short Introduction to RF Amplifiers

- Very first CONCLUSION to design a LDMOS RF amplifier:
 - the sensitive LDMOS device has to be protected by several fast acting circuitries around (hw based to react in ms, NO uProc control !)
 - at RF efficiency approx. 60% a reasonable thermal interface is mandatory
 - filter design to achieve attenuation of spurious ($< -43\text{dBc}$ up to $10 \times f_1$)
 - a cost effective telecom rectifier is needed

LDMOS RF Amplifier Design: Specifications

- In general – high power amplifier for amateur radio services on shortwave
- Must have:
 - covers all shortwave amateur bands 160m to 10m (1.8MHz to 30MHz)
 - linear amplifier to support single side band operation SSB
 - achieves 1.5kW output power without compression (legal limit US)
 - meets FCC 47 CFR 97.317 d, spurious < -43dBc (legal limit US)
- Nice to have:
 - two exciter inputs to support
 - a) SDR, low power output, typically 5W to 10W
 - b) standard transceivers, power output 100W to 200W
 - 12V / 4A bias output to supply SDR directly out of PA
 - CAT interface, frequency data out of TRX selects band filter at PA
 - smart fan control to support “silent mode” at output power <1kW

LDMOS RF Amplifier Design: Block Diagram

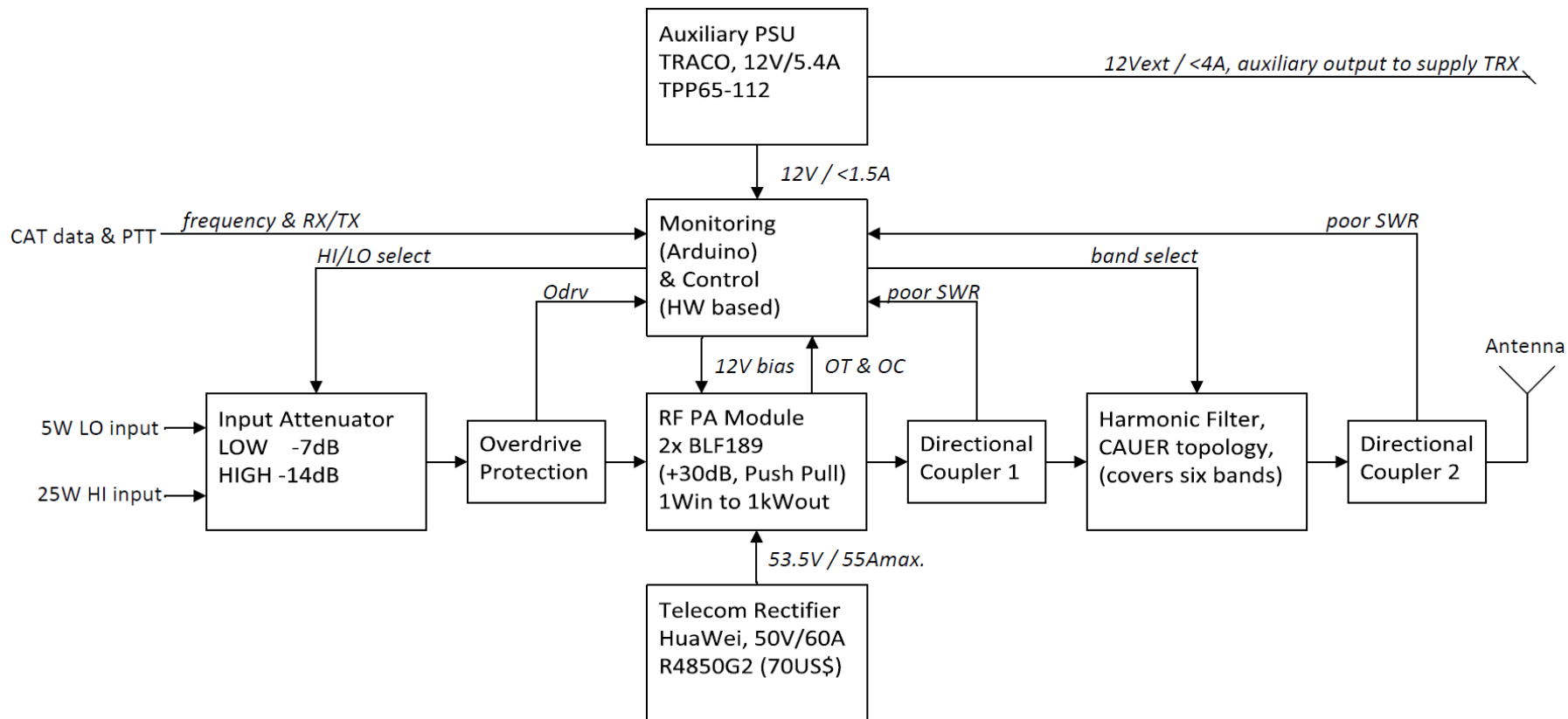

LDMOS RF Amplifier Design: RF Power Stage

AMPLEON BLF189XRB:

A 1900 W extremely rugged LDMOS power transistor for industrial pulsed applications in the HF to 150 MHz band.

Table 1. Application information

| Test signal | f (MHz) | V _{DS} (V) | P _L (W) | G _p (dB) | η _D (%) |
|-------------|------------|------------------------|-----------------------|------------------------|-----------------------|
| pulsed RF | 108 | 50 | 1900 | 26 | 72.5 |

Table 4. Limiting values

In accordance with the Absolute Maximum Rating System (IEC 60134).

| Symbol | Parameter | Conditions | Min | Max | Unit |
|------------------|----------------------|------------|-------------------|------|------|
| V _{DS} | drain-source voltage | | - | 135 | V |
| V _{GS} | gate-source voltage | | -6 | +11 | V |
| T _{stg} | storage temperature | | -65 | +150 | °C |
| T _j | junction temperature | | 1 | 225 | °C |

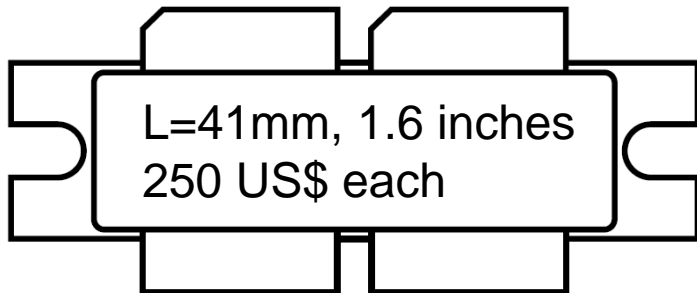

RF Power Block 2kW+:

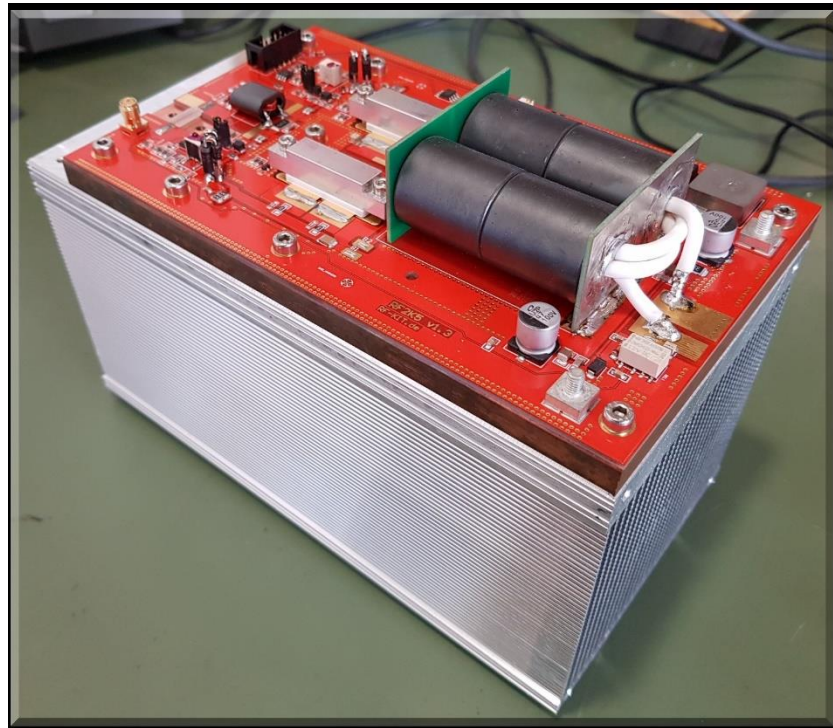

LDMOS RF Amplifier Design: 50V / 3kW Supply

Hua Wei R4850G2:

- Power Factor >99% (>50% load)
- THD <5% (>50% load)
- Effcy >95% (30% to 100% load)
- Ripple & Noise <200mVpp @ bw 20MHz
- RX/TX dynamics +/-0.5% (90% transient)

Main topic – shielded & low noise for RF circuitry:
complies to all relevant standards regarding EMC
in wireless systems, i.e. FCC, ETSI, EN, ITU...

Just replaced noisy fan, red funnel is a 3D print

Another topic: low cost for 3kW, 70\$ at “Ali” (!)

Rectifier 53.5V / 55A+ / 3kW:



LDMOS RF Amplifier Design: 50V / 3kW Supply

Further huge benefit of SMPS -
UNIVERSAL INPUT RANGE

At “Field Days” HAM radio stations are powered by generators; their output is not that well regulated as the usual grid.

Input voltage might drop as low as 176Vac for full RF output power 1.5kW+

US grid 115Vac still allows 800W+ RF output power

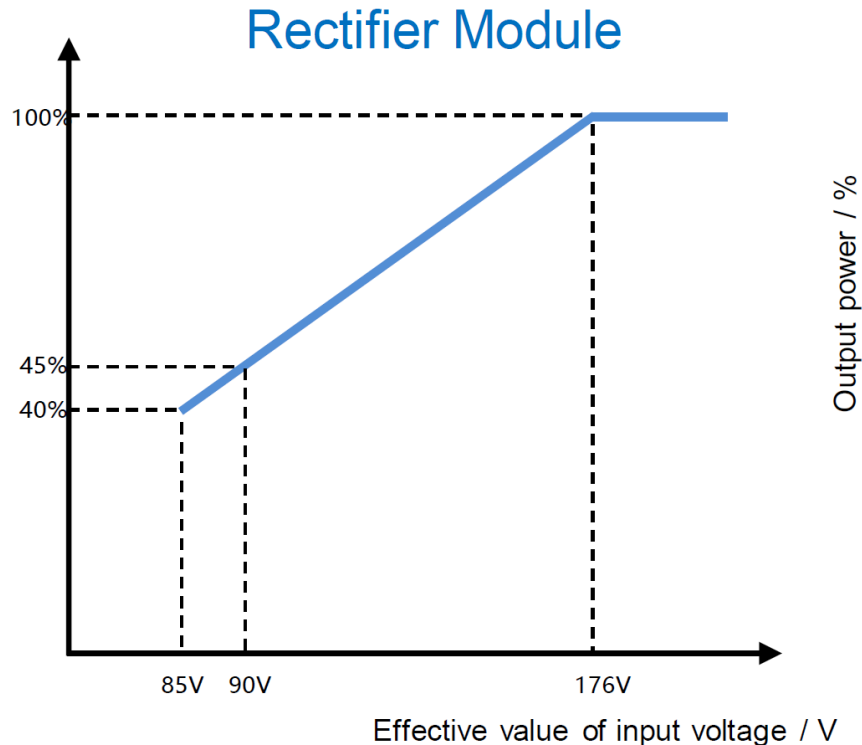

LDMOS RF Amplifier Design: 50V / 3kW Supply

Here linear power supplies of common tube amplifiers are lacking (!), those supplies are not able to withstand a large input voltage variation:

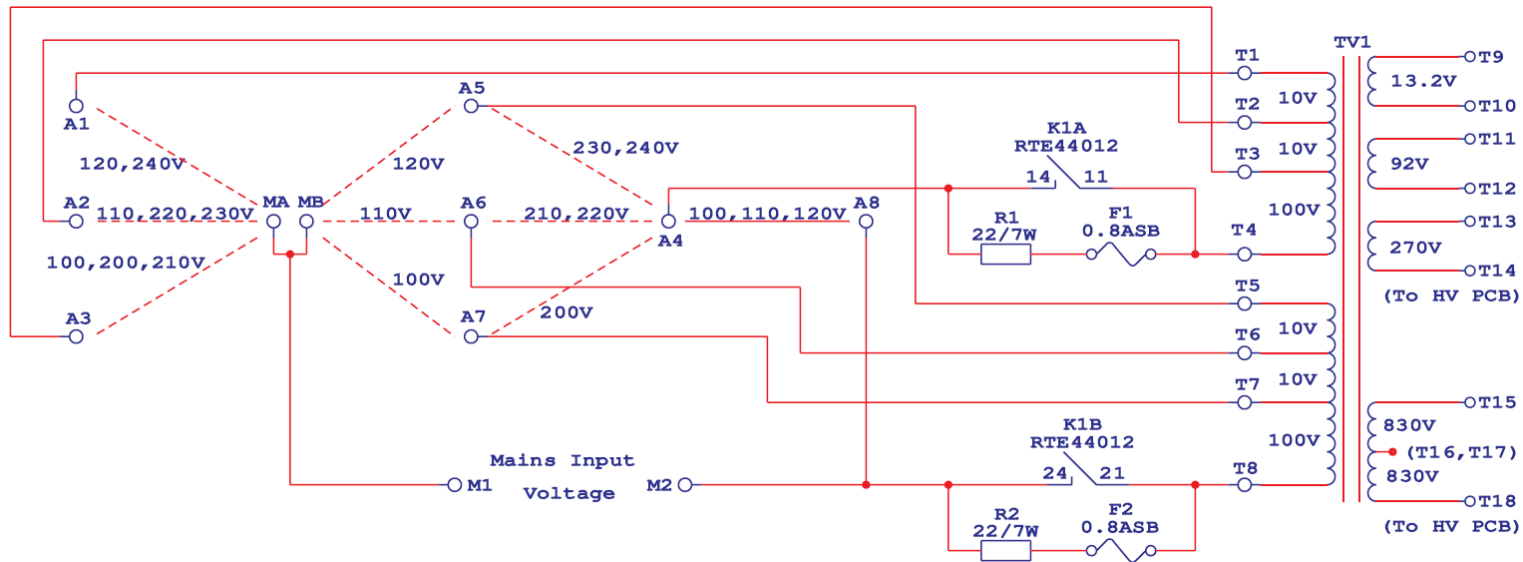

By jumpers the range needs to be set to “low line” 100V, 110V or 120V or to “high line” 200V, 210V, 220V, 230V or 240V

LDMOS RF Amplifier Design: Auxiliary PSU 12V

TRACO TPP-65112

- Efficiency 93%
- Ripple & Noise <75mVpp @ bw 20MHz
- Dynamics 3% (50% to 75% transient)
- universal input 85Vac to 264Vac

Main topic – semi shielded and low noise:
medical PSU complies to all standards
regarding EMC, i.e. IEC, EN, ES

EN-61000-4-3, withstands RF field 20V/m
(noise immunity important inside RF amplifier)

Cost: 59\$ (Mouser)

65W PSU, 12V @ 5.42A:



Deep Dive RF, Schematics Input Circuitry :

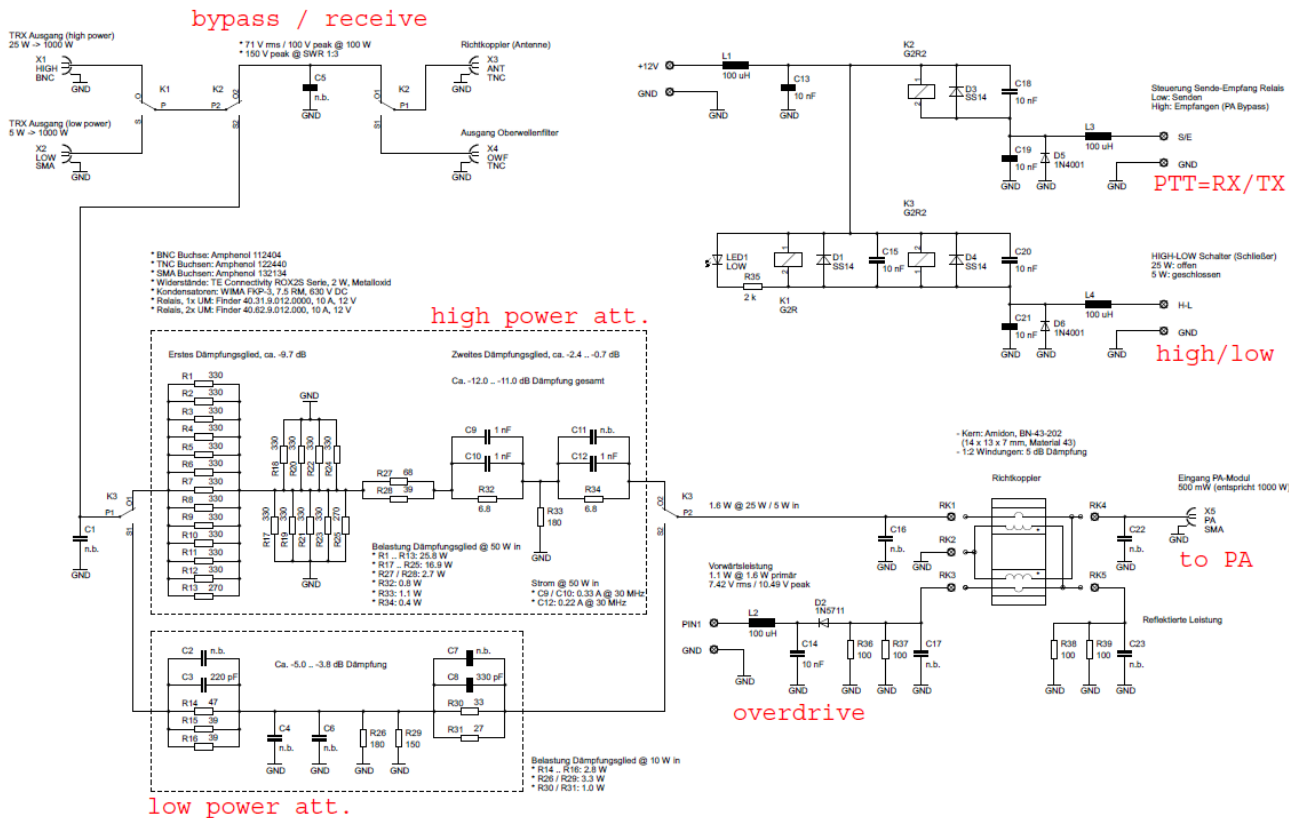

Deep Dive RF, Schematics Coupler #1:

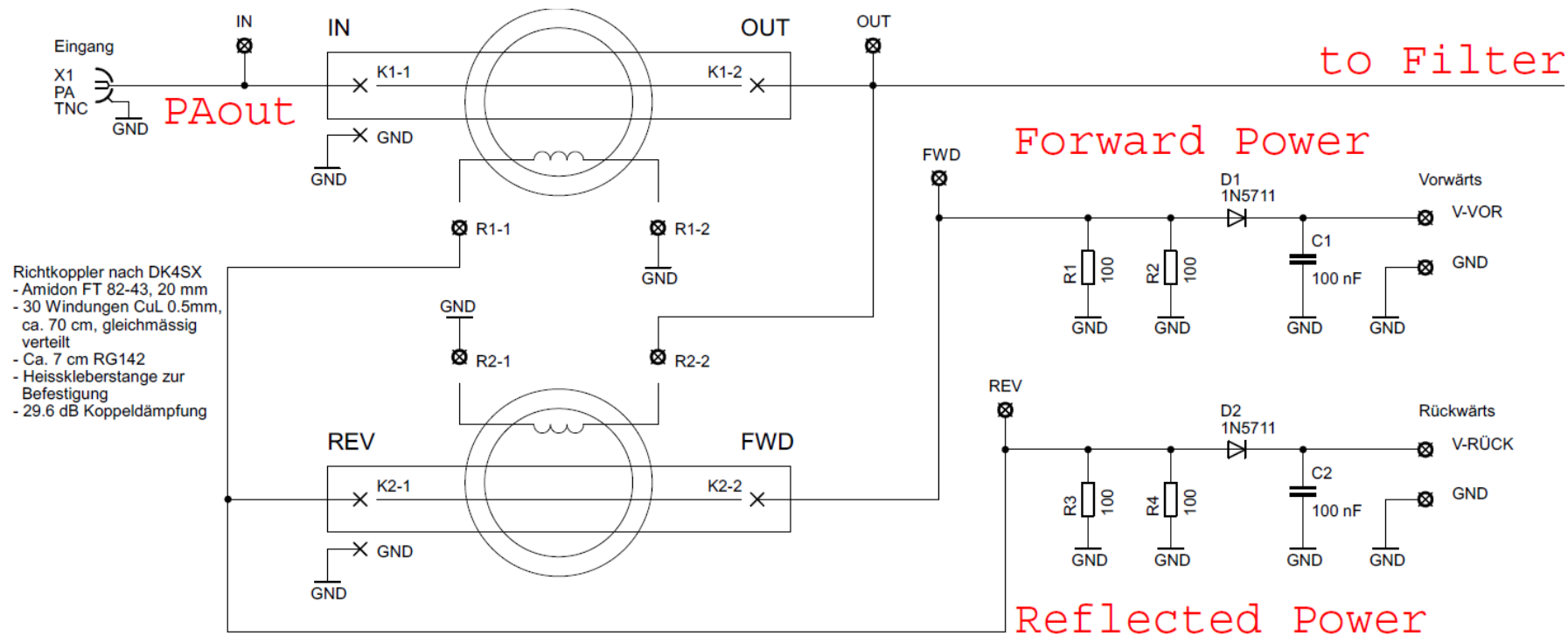

Deep Dive RF, Output Filter Design:

limited board space for SIX filters

maximum attenuation 2f1 needed

= CAUER filter (elliptic filter)

pro:

fastest transition passband to stopband

con:

equiripple behavior at passband and stopband

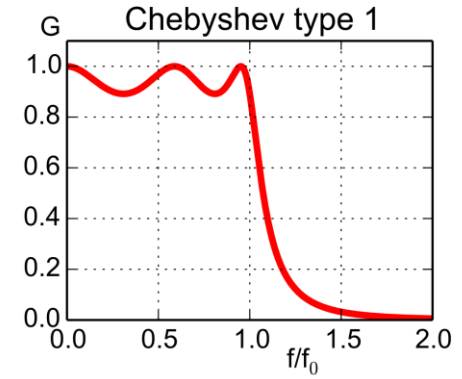
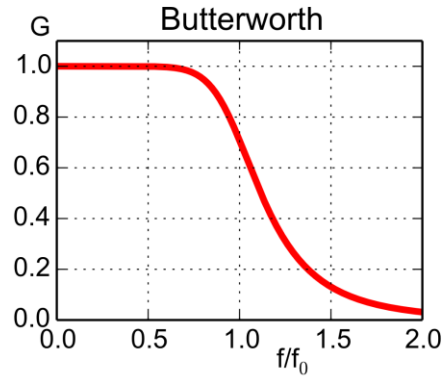

Frequency response curves for 5th order

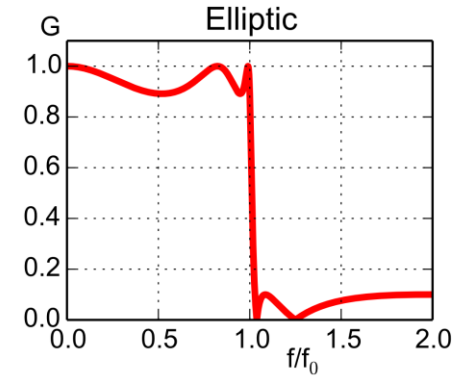
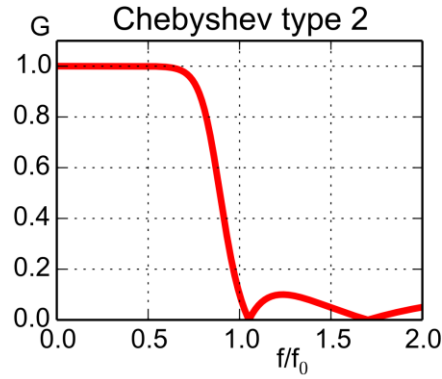

Deep Dive RF, Schematics Filter Bank:

to coupler #2

spurious suppression by RF power stage -20dB

so filter needs -25dB at 2f1

CAUER Filter 6th order, (= elliptic filter)

and:
six individual banks needed

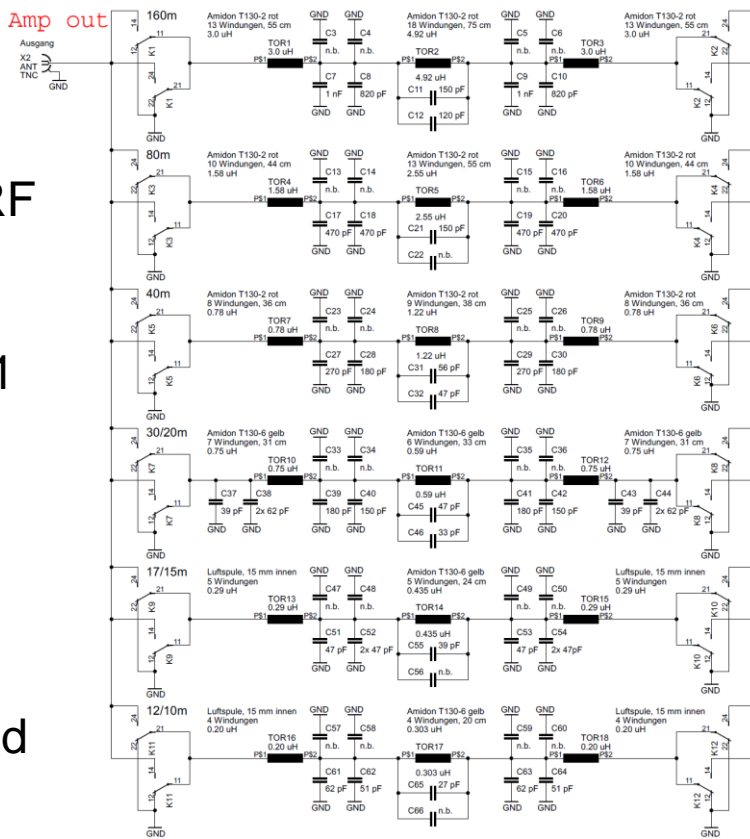

160m in

80m in

40m in

30m/20m in

17m/15m in

12m/10m in

Deep Dive RF, Filter Adjustment by nanoVNA

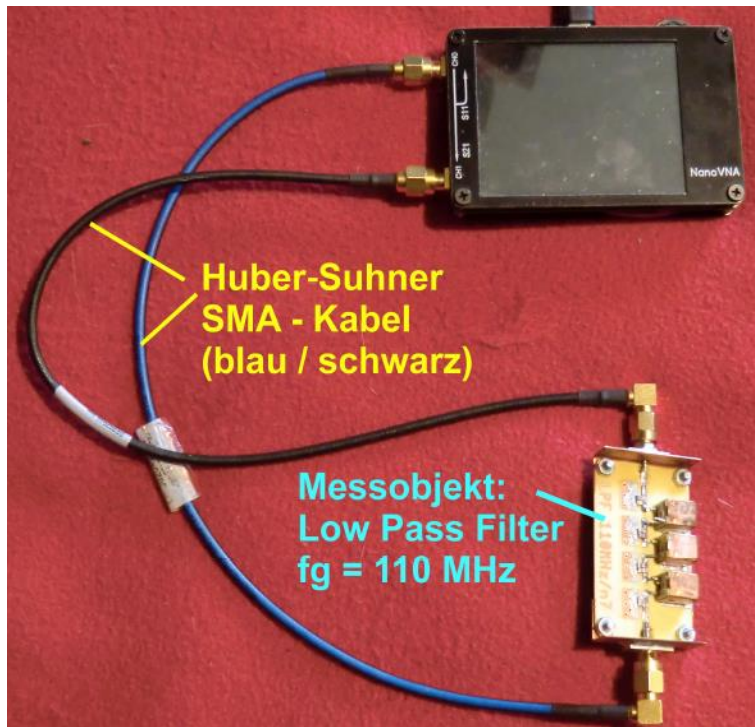

nanoVNA H4, <100 US\$

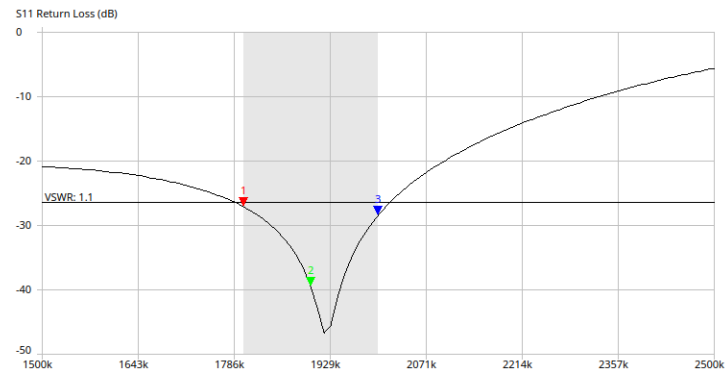
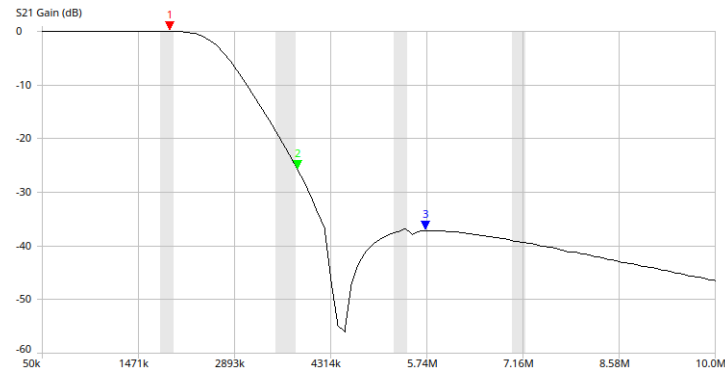

Adjustment 160m filter (1.8MHz)

Deep Dive Peripherals, Schematics PA Interface:

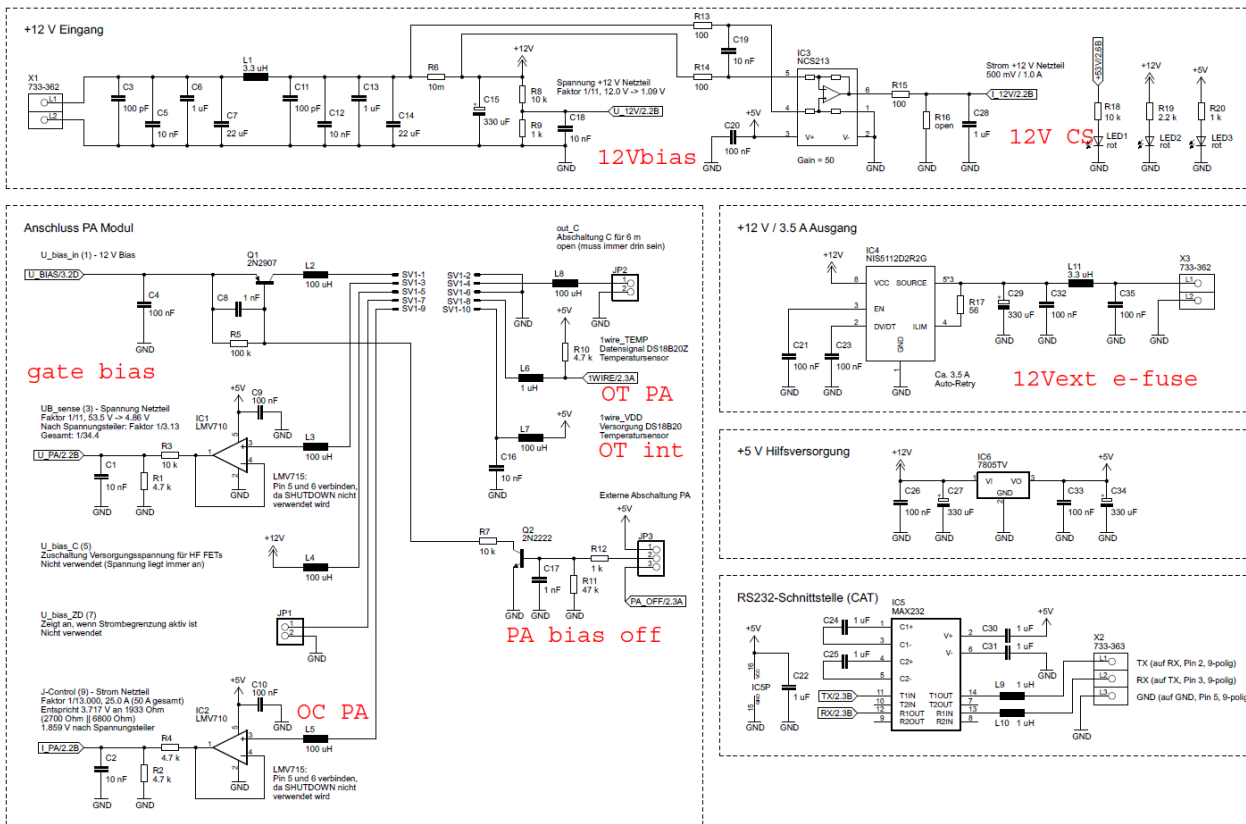

Deep Dive Peripherals, Schematics PA Control:

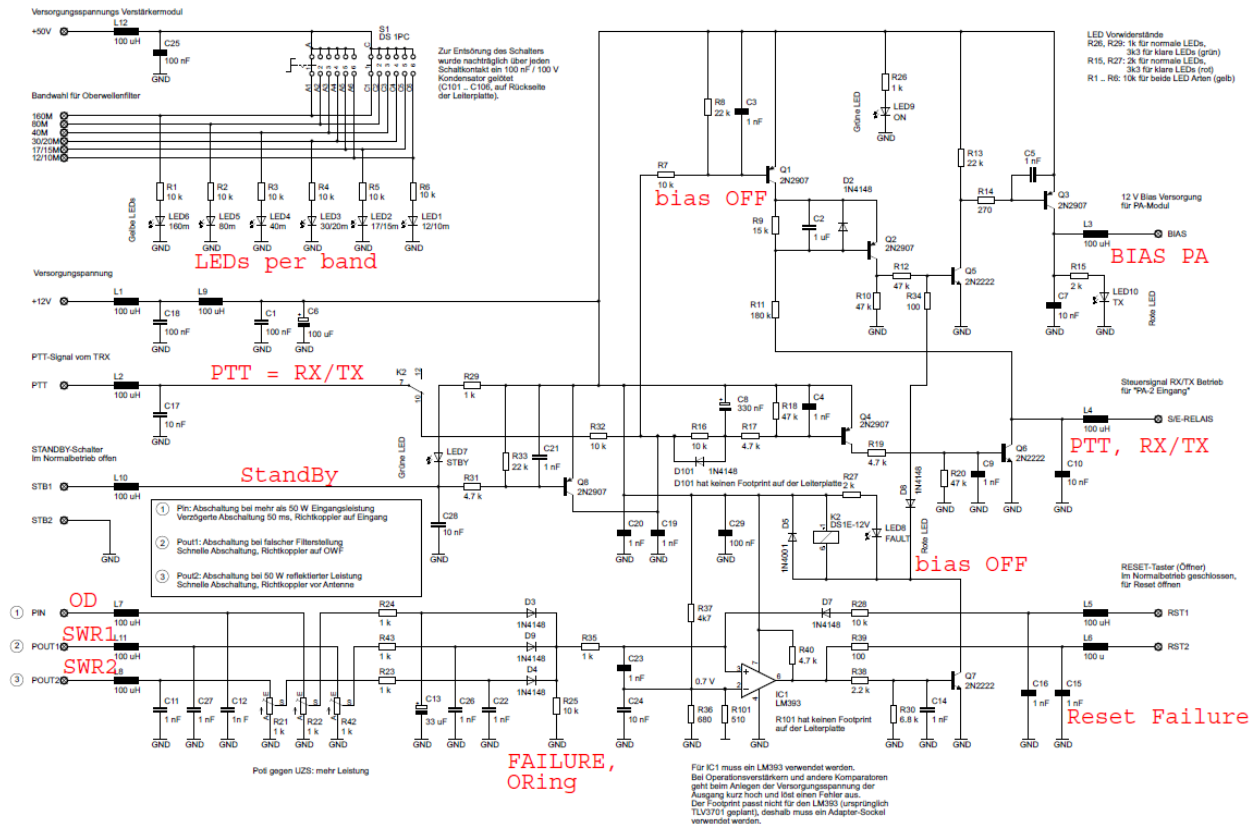

Deep Dive Peripherals, Schematics Fan Control:

Fan Control Rev2:

- used 48V fans
- analog control very lossy !
- switched to PWM control
- Arduino measures temp.
- Arduino sets duty cycle
- <40c fan off
- 40c 20% duty, +2.35% / c
- 55c 55% duty, +4.70% / c
- 65c 100% duty
- >65c ALARM (buzzer)

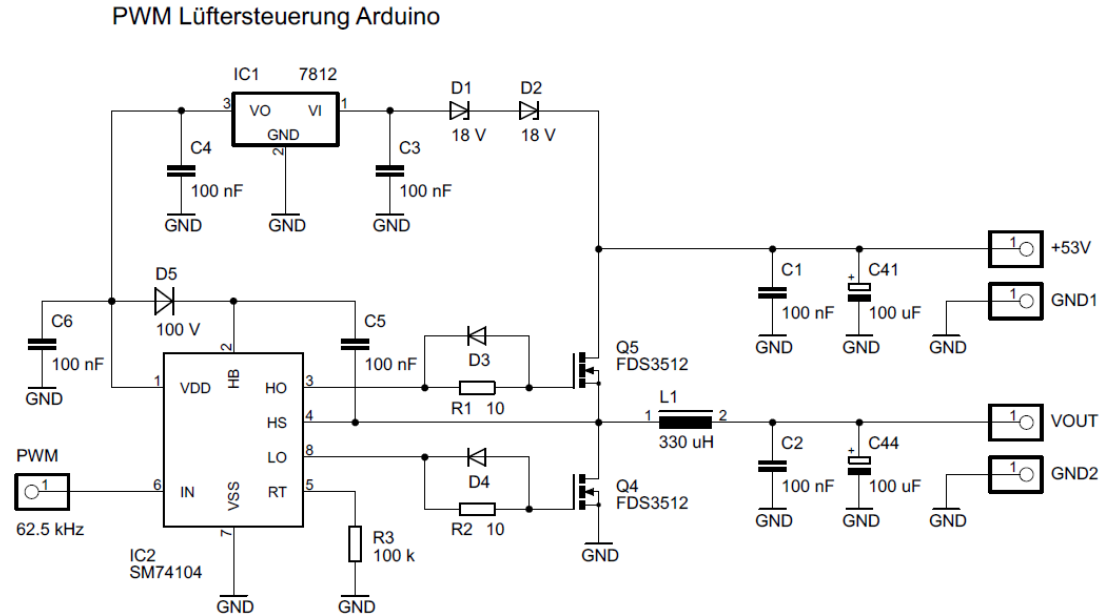

Deep Dive Peripherals, Fan Characteristics Rev2:

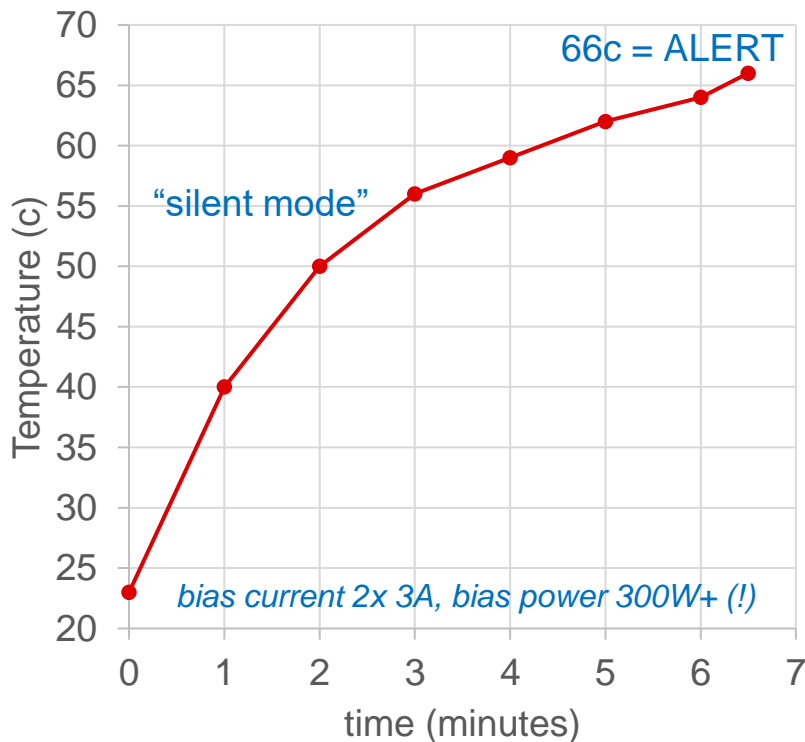
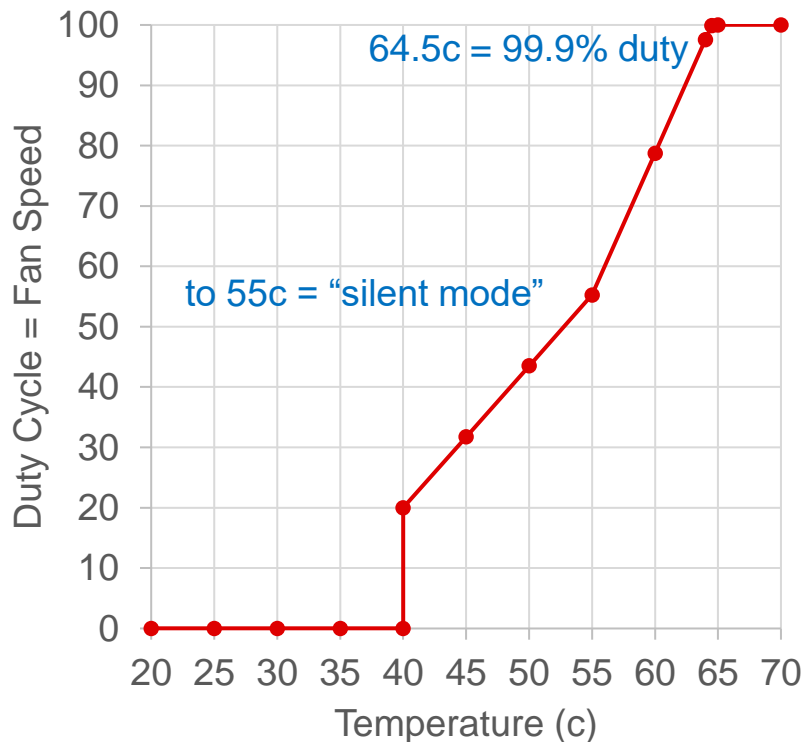

Stress Test: Id set to 20A, Pout 320W, Pdc 1070W, Pv 750W, Effcy = 30% (HF) ²²

LDMOS RF Amplifier Design, Hardware Pictures:



Input Att + LDMOS



Coupler



Band Filters

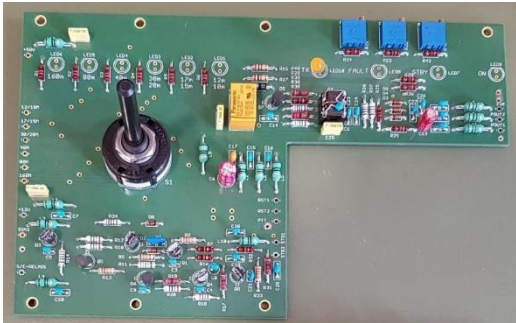

Control



FAN v2



CAT

UNO rev3 FAN v1₂₃

LDMOS RF Amplifier Design, BETA Symbiosis:

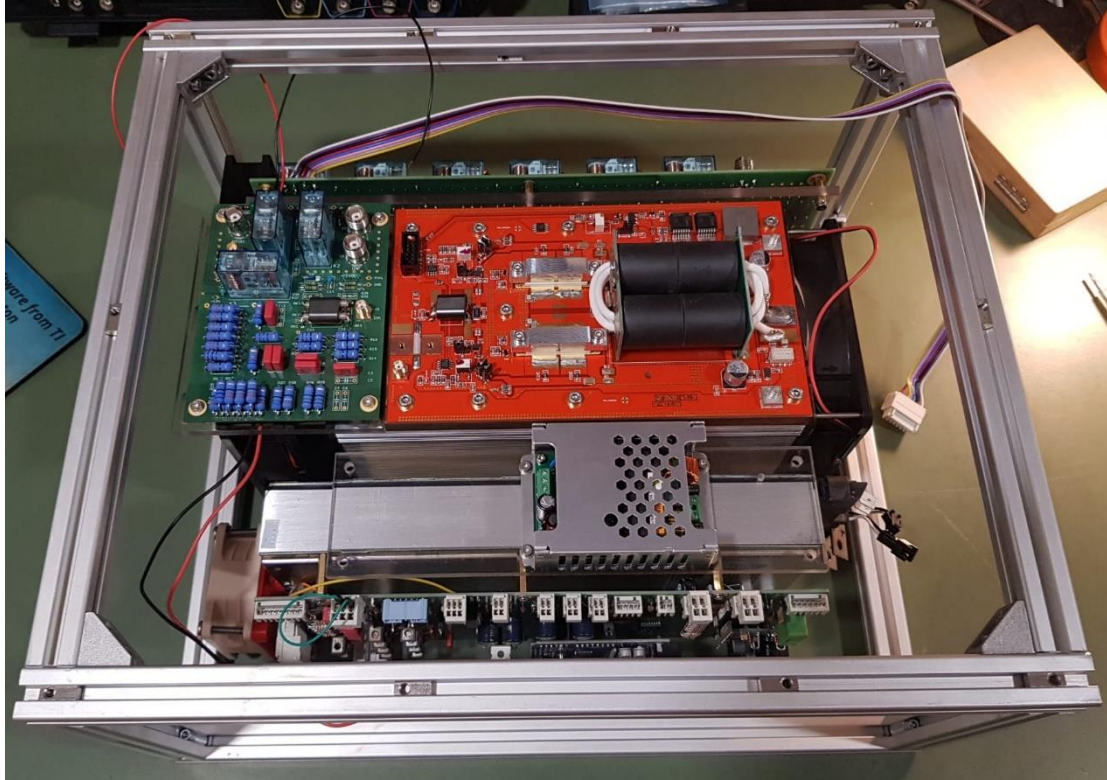

Subassemblies mounted into BOSCH frame

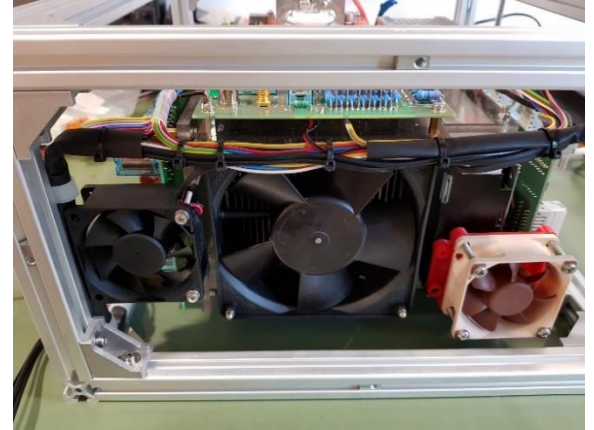

Thermal Management



Control & Displays

LDMOS RF Amplifier Design, WK Mechanik:

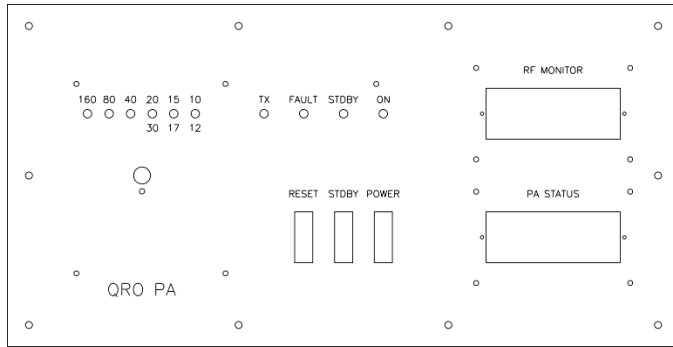

Front Plane, CAD

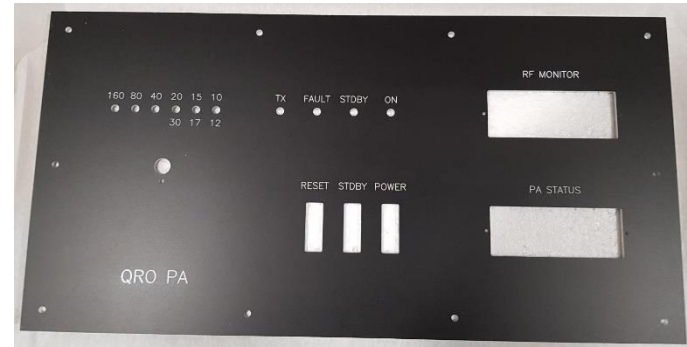

Front Plane, HW



added Subassies



ALPHA, very first check...

LDMOS RF Amplifier Design, a) TRX TIMING:

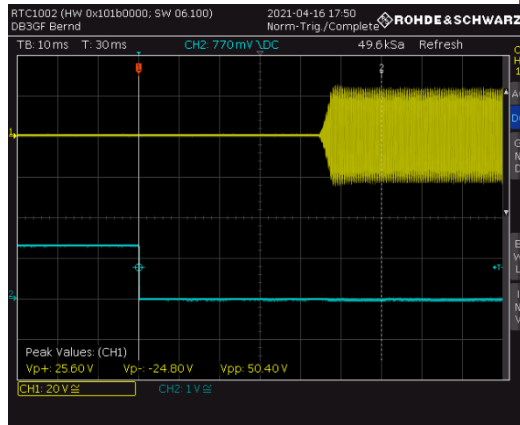

RF output

PTT, low active

CW, RX to TX

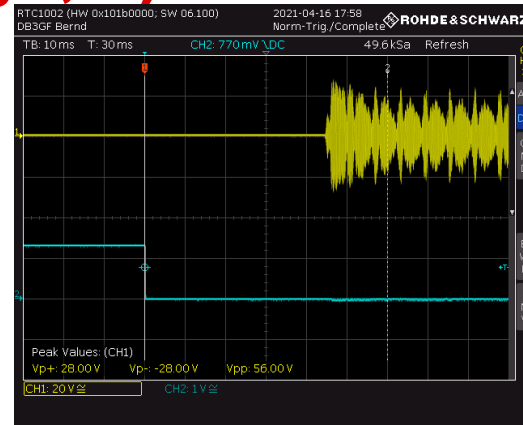

SSB, RX to TX

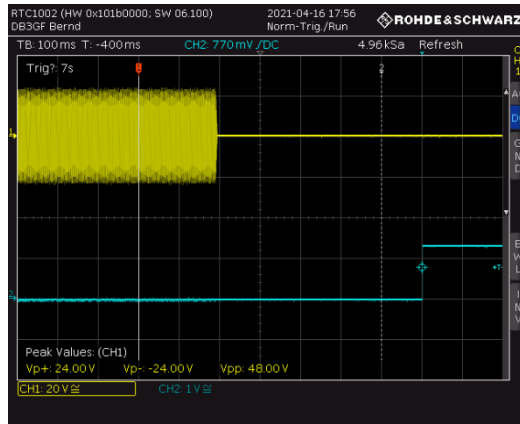

CW, TX to RX

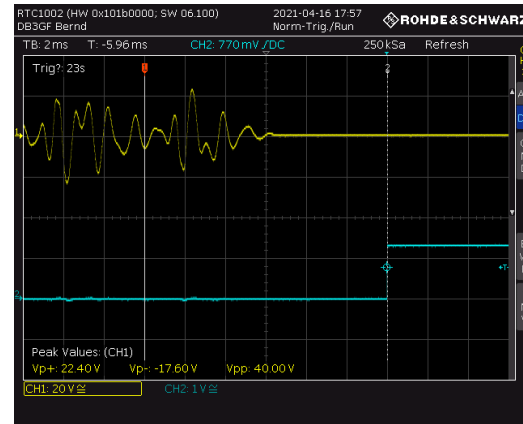

SSB, TX to RX

LDMOS RF Amplifier Design, a) TRX TIMING:

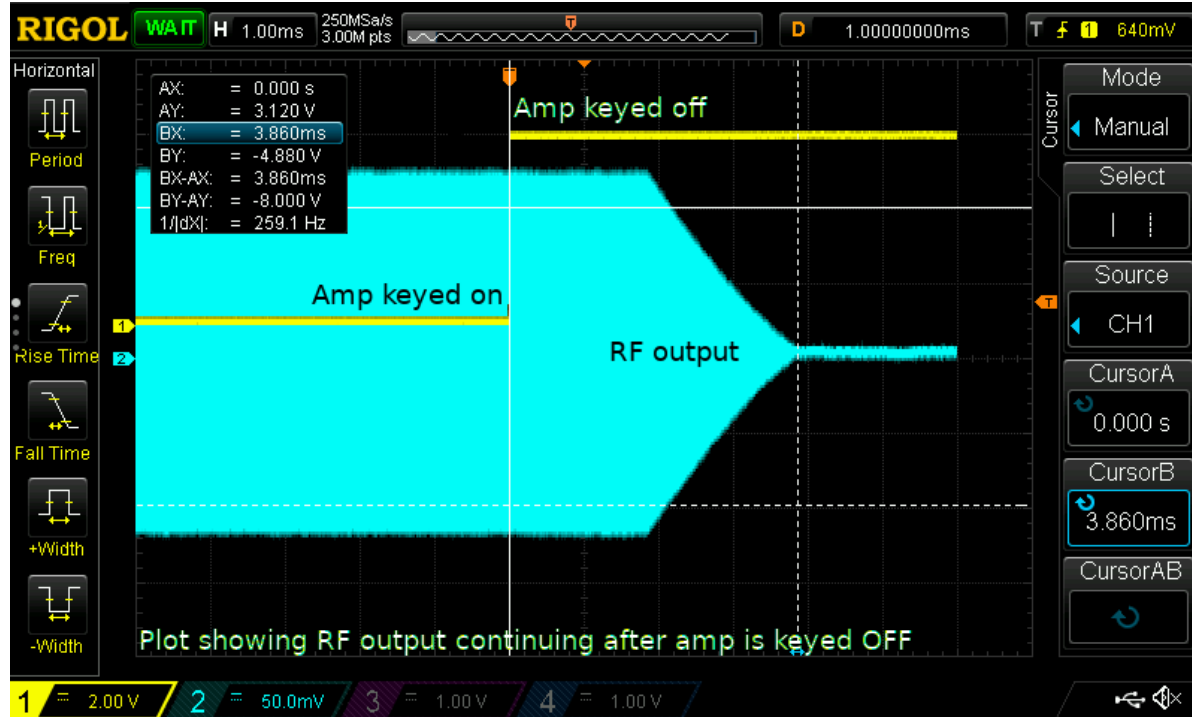

PTT, low active

RF output

very poor example of TRX timing – **IC-7300**, here CW, TX to RX:
PTT release kills SPE expert amplifiers...

LDMOS RF Amplifier Design, b) TRX OVERSHOOT:

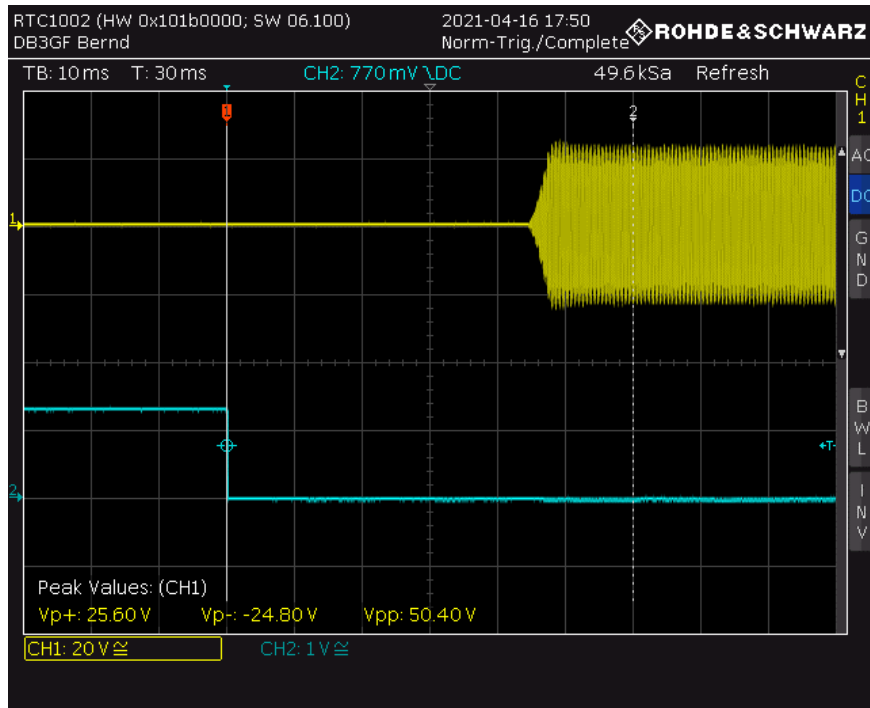

Exciter TS-890S, small overshoot

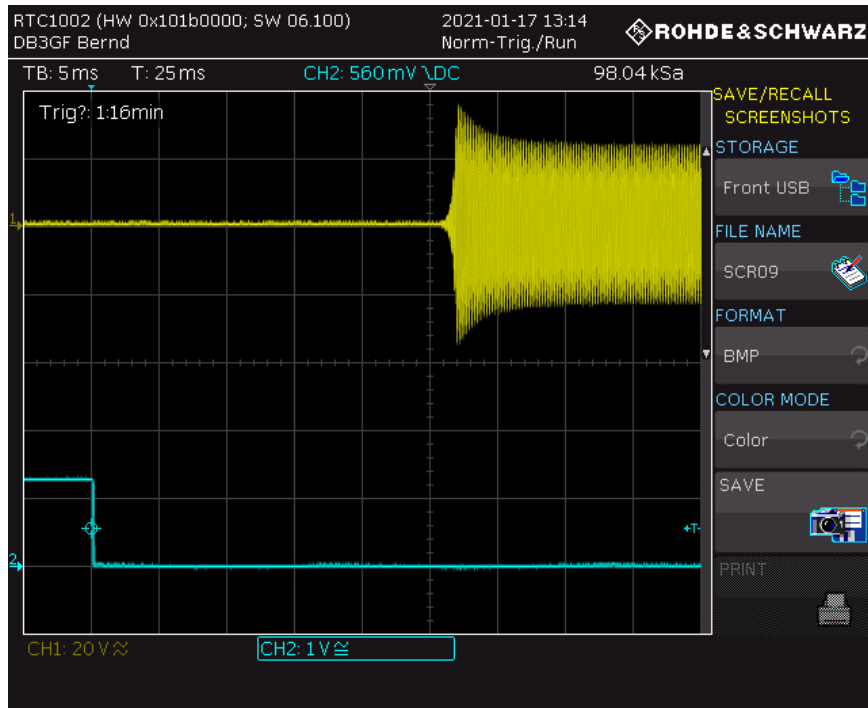

Exciter TS-570DG, large overshoot (!)
needs gate protection (clamping)

LDMOS RF Amplifier Design, c) TRX SPURIOUS:

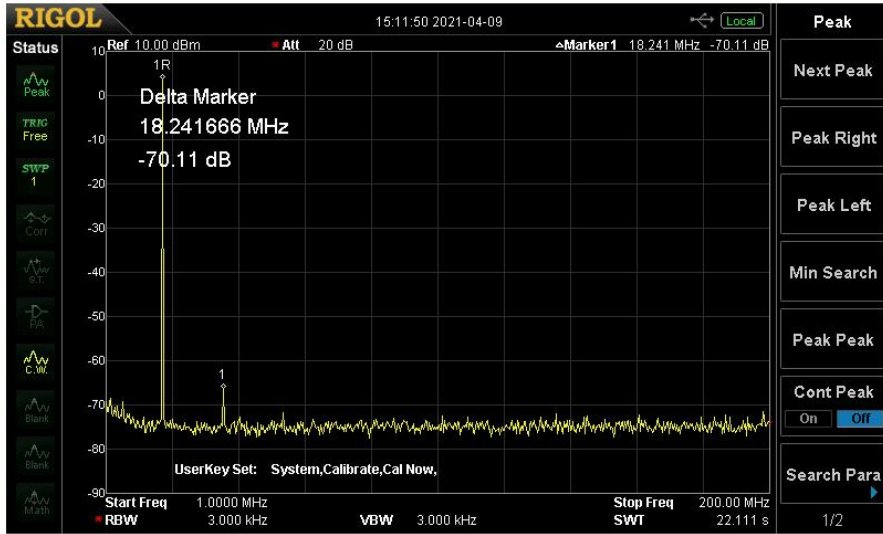

Exciter TS-890S, 17m band, -70dBc

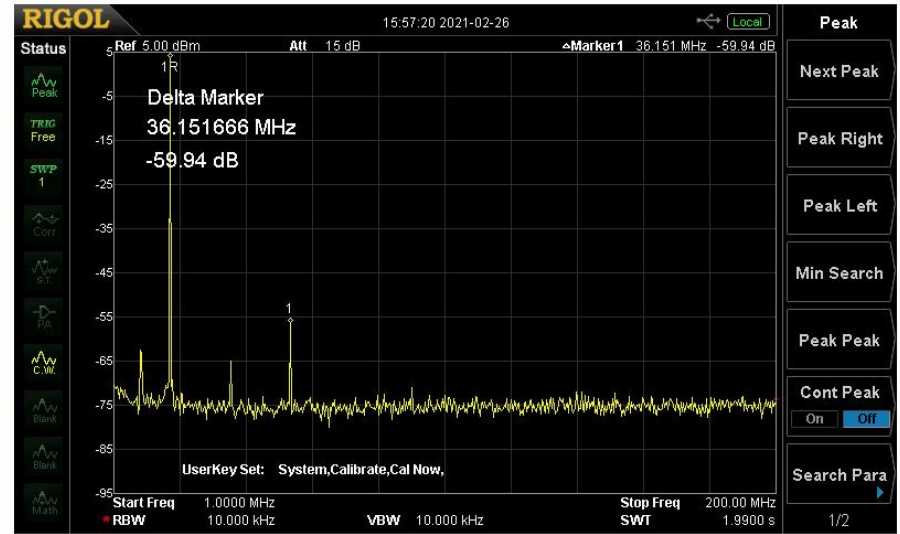

Exciter TS-570DG, 17m band, -60dBc, 3f1 is strong, plus subharmonic noise

LDMOS RF Amplifier Design, On The Bench:

Spectrum Analyzer

Exciter Kenwood TS-890S

EUT QRO PA

Power Analyzer

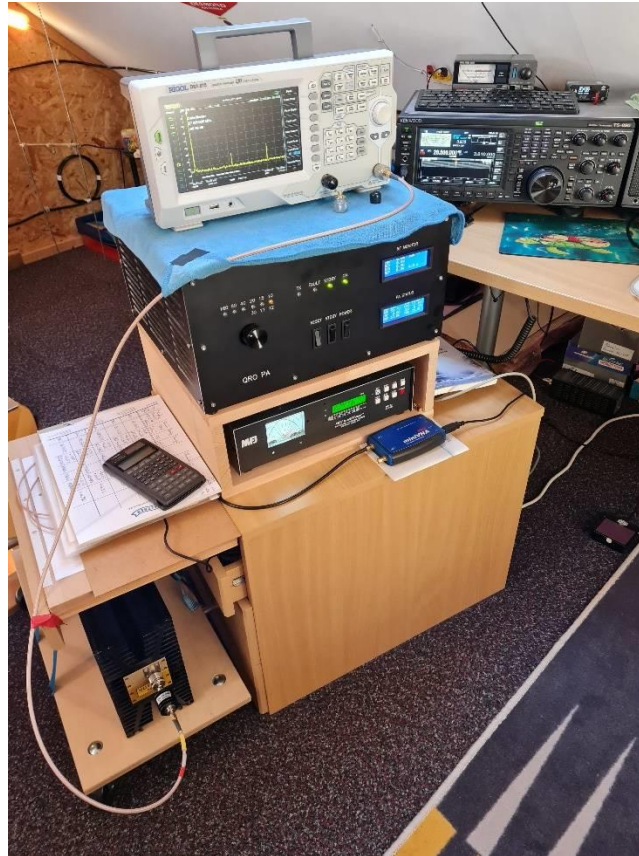

Attenuator 2kW / -30dB
Attenuator 10W / -30dB
(1kW to 1mW = 0dBm)

LDMOS RF Amplifier Design, Example 17m/18MHz:

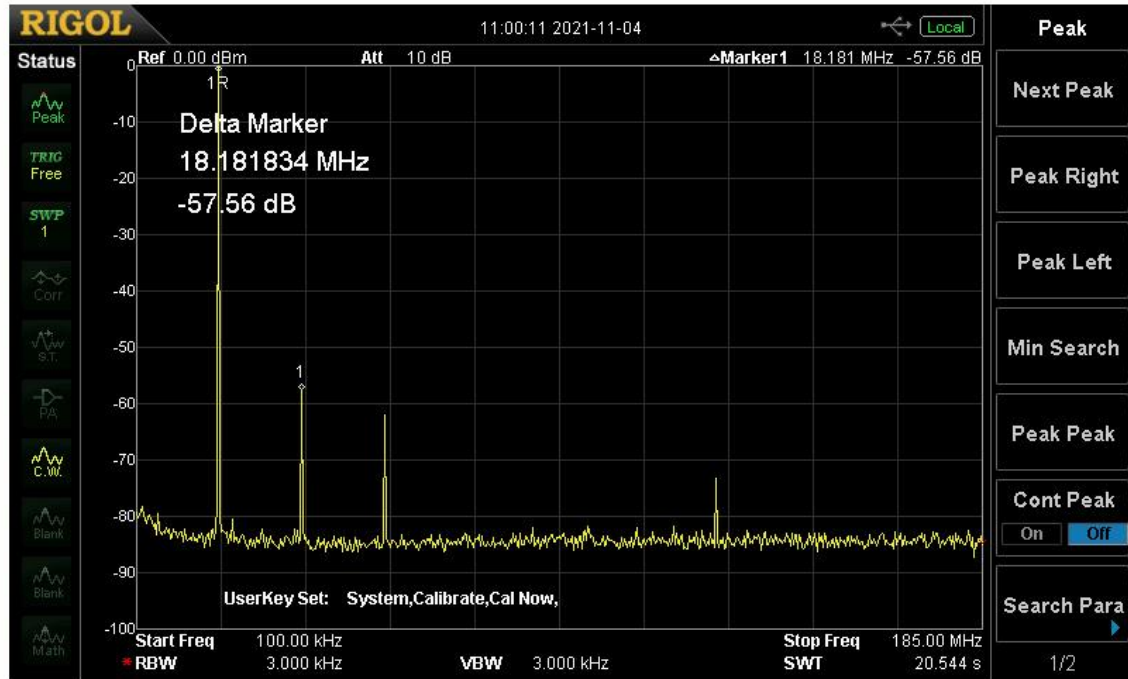

Measurement up to 10f1 mandatory – see here, 7f1 (!)

LDMOS RF Amplifier Design, Results:

Summary for #002, Spurious Emissions § 97.307 (d) at Output Power approx. 1kW:

| Band | Frequency f1 MHz | 2f1 dBc | 3f1 dBc | 4f1 dBc | 5f1 to 10f1 dBc |
|-------------|---------------------|---------------|---------------|------------|--------------------|
| 160m (900W) | 1.900 | -64.01 | -48.32 | n/a | -76.58 |
| 80m | 3.650 | -69.06 | -49.93 | n/a | -77.54 |
| 40m | 7.100 | -66.26 | -60.86 | n/a | -63.65 |
| 30m | 10.125 | -61.50 | -56.14 | n/a | n/a |
| 20m | 14.175 | -67.22 | -62.15 | n/a | n/a |
| 17m | 18.120 | -57.88 | -62.01 | n/a | -73.29 |
| 15m | 21.225 | -68.73 | -69.92 | n/a | n/a |
| 12m (900W) | 24.940 | -71.27 | -47.23 | n/a | -67.30 |
| 10m | 28.500 | -66.31 | -66.65 | n/a | n/a |

LDMOS RF Amplifier Design, Results:

Power & Gain in Depth, measured for #003 only – achieved gain around +17dB at HIGH input:

| Band m | Att “-60dB” | TX “25W” | PA mtr | MFJ mtr | SA “1kW” | Gain dB | Drain Ampere |
|-------------------------|-------------|-----------------------------|--------|---------|----------------------------------|---------|--------------|
| 160m -44.3dBc | -60.25 | -16.89 +43.36 = 21.7W | 930W | 840W | -0.58 +59.67 = 927W | +16.3 | 42 |
| 80m -51.0dBc | -60.35 | -16.84 +43.51 = 22.4W | 1100W | 1060W | +0.27 +60.62 = 1153W | +17.1 | 42.5 |
| 40m -64.0dBc | -60.50 | -16.94 +43.56 = 22.7W | 1140W | 1110W | +0.34 +60.84 = 1213W | +17.3 | 40.5 |
| 20m -62.4dBc | -60.50 | -16.96 +43.54 = 22.6W | 990W | 970W | -0.33 +60.17 = 1040W | +16.6 | 40.5 |
| 10m -67.0dBc | -60.6 | -17.07 +43.53 = 22.5W | 1040W | 970W | -0.17 +60.43 = 1104W | +16.9 | 43.0 |

calibrated Spectrum Analyzer (SA) provides reasonable results;

for similar gain RF power stage needs slightly bigger RF coupling capacitor at input, results at 160m: gain 16.9dB, output power 1100W;

gain across bands: 16.6dB to 17.3dB

For use at the United States of America maximum gain needs to be less than 15dB, see FCC 47 CFR §97.317 (a) (2);

Outlook QRP PA ALFA mark II

DIGITAL PREDISTORTION:

The second directional coupler offers an attenuation of -30dB to the power meter, means 1.5W forward power at 1.5kW output power.

Further decoupling of -20dB (windings ratio 1:10) offers a RF signal of 15mW – that's the needed input level (+20dBm max.) to drive the predistortion input "TX SAMPLE INPUT" of Elecraft K4.

A small SMA attenuator -12dB enables to drive other SDRs by 0dBm feedback level.

Doing so the RF bias current could be reduced by keeping the high linearity, results in less losses and improved efficiency.

An effective two tone and noise setup has already been designed.
(*hardware based, soundcard based and .WAV - player based*)

Outlook QRP PA ALFA mark II

ENVELOPE TRACKING:

RF bandwidth of SSB signal is typically less than 3kHz; the predistortion feedback signal offers the envelope information, too !

This AF information is forwarded to the feedback of the 50V power supply, a small bias current is injected into the resistive feedback divider.

(loop bandwidth of the power supply needs to be >6kHz, 9kHz is recommended)

Doing so, the output voltage of the telecom rectifier is modulated by the AF, the drain voltage is kept roughly only 5% beyond the needed RF voltage.

Difference in between drain voltage and RF envelope are simply the losses.

So envelope tracking of the drain voltage reduces losses significantly, relieves the thermal interface and reduces thermal stress.

EER (Envelope Elimination and Restoration) has not been taken in account, modulator and demodulator hardware is way too much effort.

Summary QRP PA (QRO = increase power)

Three LDMOS based solid state amplifiers for amateur radio services have been designed, built, tested - and are ON AIR since April 2021

The amplifier itself delivers 1.5kW+ output power on all shortwave bands 160m to 10m, so 1.8MHz to 30MHz

The amplifiers are FCC compliant regarding spurious emissions

At low line input 115Vac the output power is limited to 800W

**DRAWBACK – needed much more time as expected (>10x),
CONSTRUCTION MANUAL here: <https://www.dk9mat.darc.de/>**

**BIG THANKS to om Uli (DK4SX) mentoring us for one year...
BIG THANKS to om Reinhard (DH3NAB) for RF support...**

Appendix, LDMOS RF Amplifier, EQUIPMENT

To verify such an amplifier some basic equipment is needed:

- *reasonable exciter*
 - *high power attenuator 2kW plus low power attenuator 10W or high power directional coupler and dummy load 2kW*
 - *7/8 inch, sensor based RF power meter, Bird Electronics or Coaxial Dynamics*
 - *2-channel, better 4-channel scope, bw >300MHz*
 - *calibrated spectrum analyzer, RIGOL DSA 815-TG is fully sufficient*
 - *network analyzer, audio analyzer (software based via best soundcard works)*
 - *2-tone generator and/or white noise generator and/or excellent sound card*
 - *all kind of adapters, attenuators, cabling...*
- + well equipped work bench**

Appendix, LDMOS RF Amplifier, EXCITER

REASONABLE EXCITER - the amplifier can't correct a poor driver !

Please measure spurious and IMD3 of your transceiver or check at SHERWOOD, some well suited classic shortwave transceivers IMD3 better -40dBc:

- YAESU FTDX 5000 D
- Kenwood TS-890S (tuned)
- ELECRAFT K3S
- Kenwood TS-590SG
- ICOM IC-7610

Modern SDRs offer even better IMD3 (-50dBc - and beyond !)



Appendix, LDMOS RF Amplifier, EXCITER

Design your input attenuator for best performance range of your TRX !

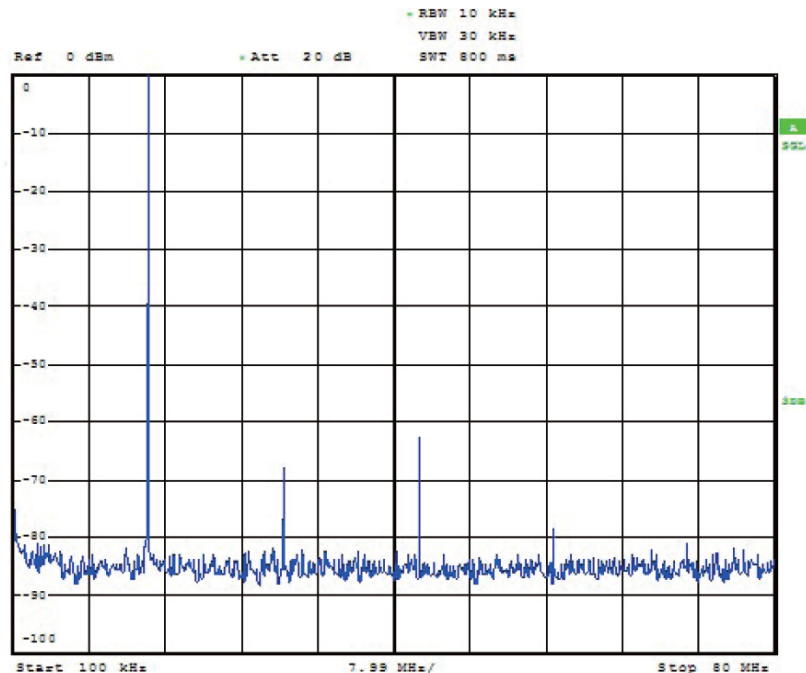
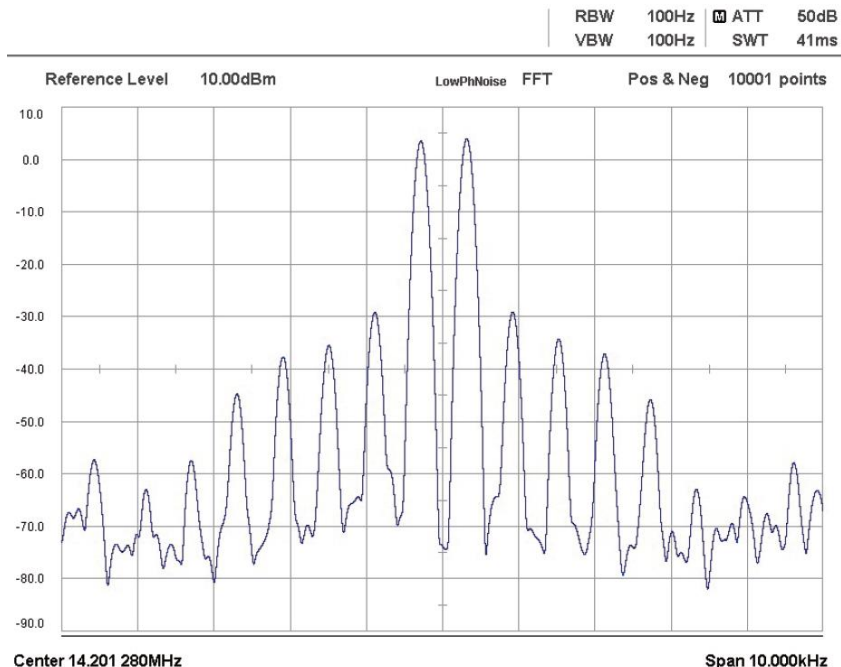

here: TS-890S at full power 100W – best performance around 30W to 35W

Appendix, LDMOS RF Amplifier, RF POWER 1kW+

To measure the output power a dummy load and a power meter is needed;
for spurious and IMD3 a total attenuation of 50dB to 60dB is needed,
1kW output power attenuated to 10dBm to 0dBm (10mW to 1mW at 50 Ohms)



expensive



versus

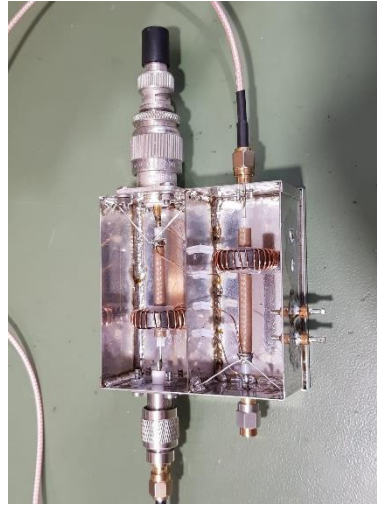

affordable

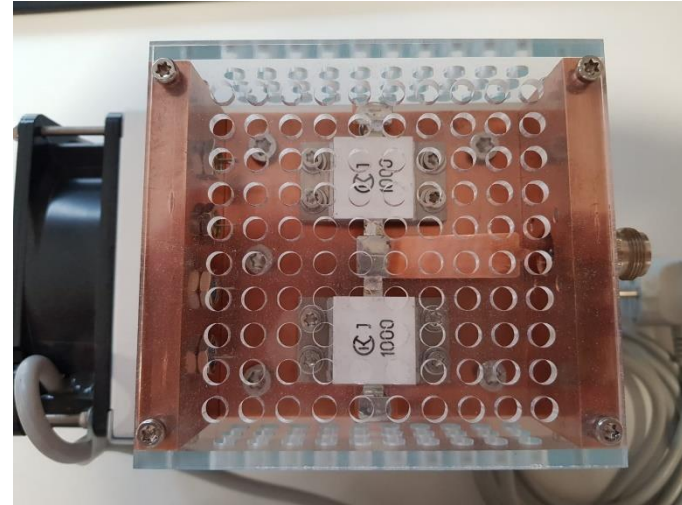

Appendix, LDMOS RF Amplifier, IMD3

For two tone measurement the simple MP3 player using files did not work well; classic two tone generator or the tuned **sound card SB1095 works best**; a simple white noise generator is well suited – and the hardest measurement !

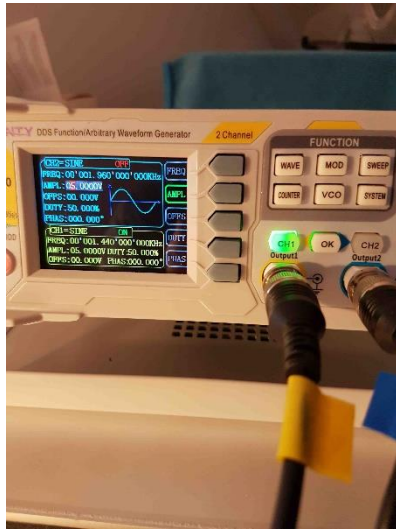

expensive

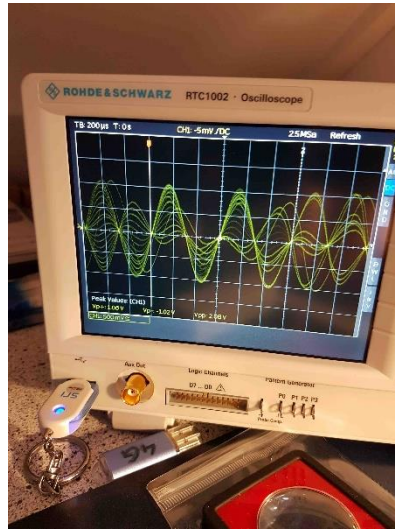

versus



affordable

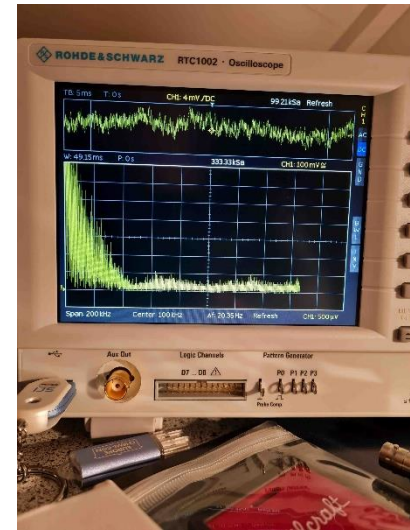

Appendix, LDMOS RF Amplifier, IMD3 via SB1095

take a Sound Blaster “SB1095” and follow the modifications of **IW3AUT**;
install “Real Time Audio Spectrum Analyzer” of **GM8ARV**:

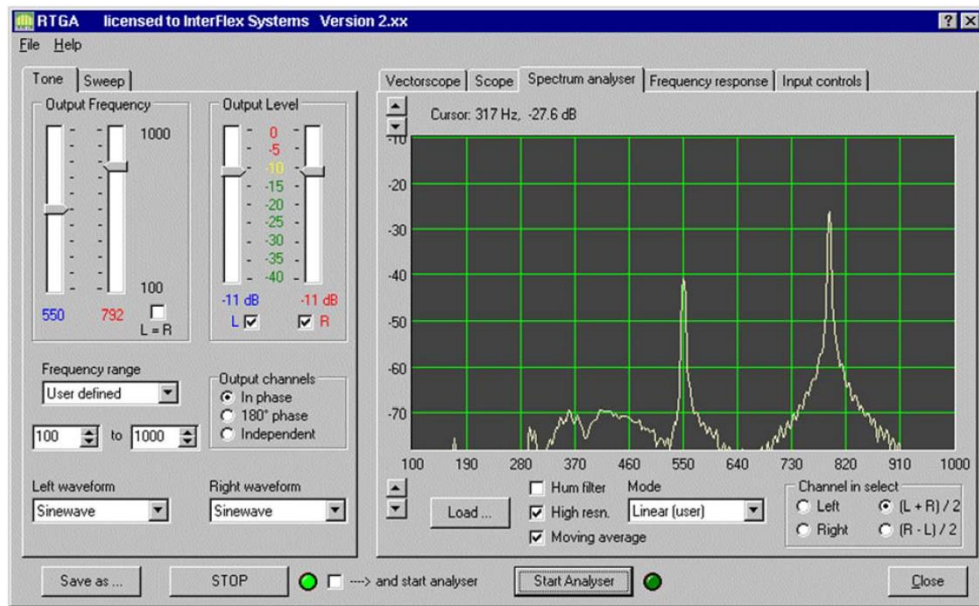

This setup allows either the analysis of any audio equipment or drives your TRX directly.

Single tone, two tone, white noise and pink noise available.

Use audio transformer at mic input, i.e.

“GT elektronik SV1-500A”

Appendix, LDMOS RF Amplifier, some more pics



FCC @ BETA, TS-570DG



BETA on air, 750W+

Appendix, LDMOS RF Amplifier, some more pics



BETA, thermal test 1.3kW+ continuous



ALPHA, solid as a rock